

Pipe and Tube System

The Safe Way to Disposal.

- ✓ Individually adaptable to each laboratory
- ✓ Reaches every corner
- ✓ High tensile strength
- ✓ 100% sealed



The tubular system: safe attachment, optimum flow direction

The SymLine FLEX tube extensions have a funnel-shaped threaded sleeve at one end and a smooth tube opening at the other. In order to tightly interconnect the tubular system, the threaded sleeve, clamping ring and sealing ring are simply pushed over the smooth end of one tube, and this is then firmly screwed on to the threaded part of the following extension piece (i.e. on the other tube). When done properly (tightening torque 10 - 15 Nm), the resulting connection will withstand a tensile force of **400 N**. The system allows for optimum flow of waste liquids and prevents leakage.

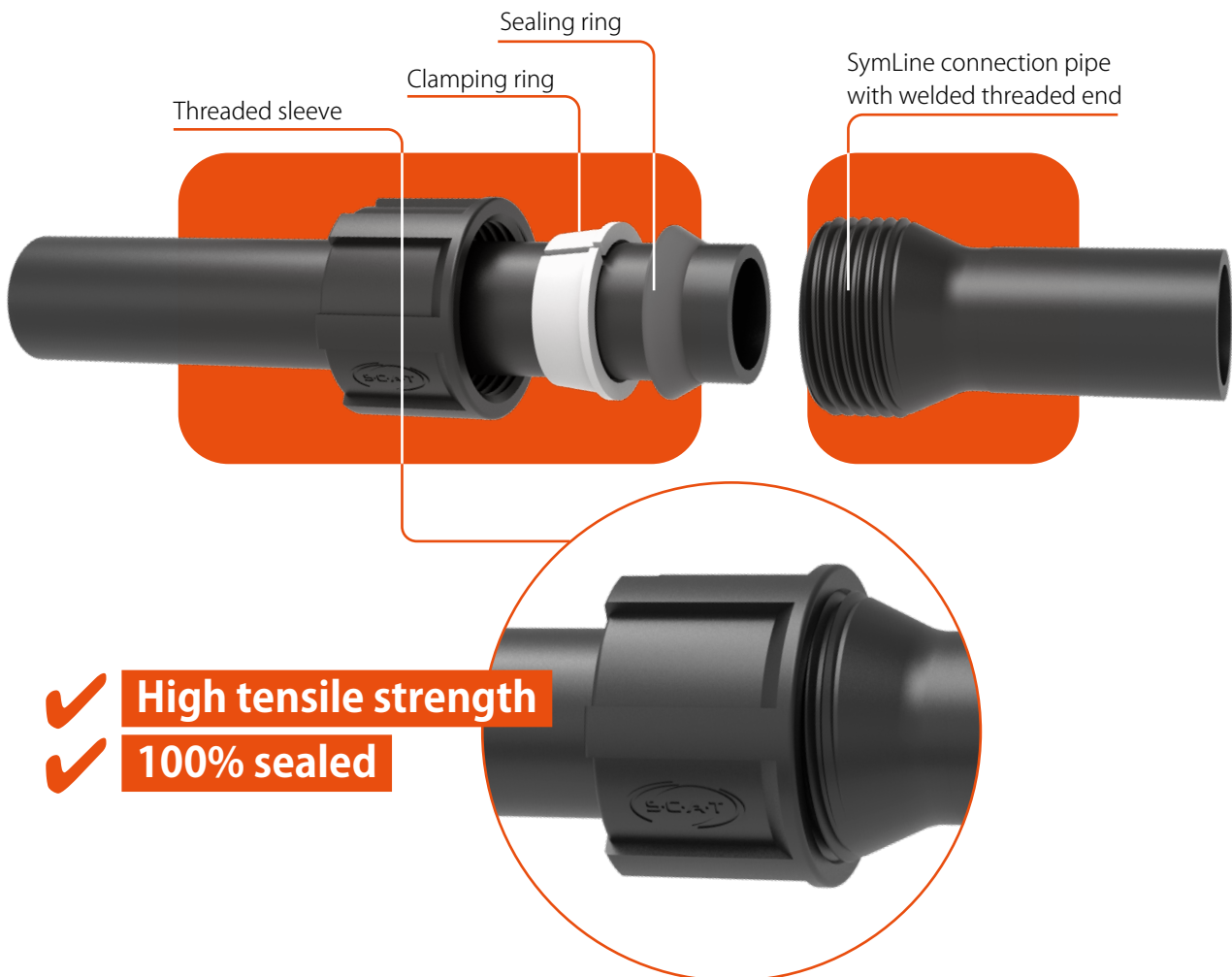

SymLine material properties

All components made of electrostatically conductive plastic can be earthed and are suitable for voltage equalization, as per TRGS 727. Electrically conductive PE-HD-EL displays a discharge resistance against earth of $< 10^9 \Omega$, as per DIN EN 61340-5-1, and is suitable for Zones 0, 1 and 2, as per the German Hazardous Substances Ordinance (ATEX), EN 1127-1, DIN EN 60079-10-1 and DIN EN 60079-10-2. It is resistant to chemicals, as defined in SEFA 3 and SEFA 8.



- TRGS 727
- DIN EN 61340-5-1



- ATEX zone 0, 1 and 2
- EN 1127-1



- DIN EN 60079-10-1
- DIN EN 60079-10-2



- SEFA 3
- SEFA 8

Pipe system

The principle "smooth tube end runs in funnel-shaped threaded socket" optimally leads waste liquids and prevents leaks. This SymLine design is the global standard for all types of waste disposal cycles and their installations. Trust SymLine - the market leader - for safe disposal.

SymLine construction method - optimal for waste transport

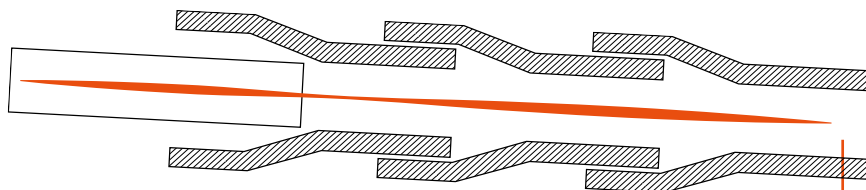

SymLine construction, with optimum liquid flow.
Liquids flow continually downwards, from the smooth pipe end, into the interconnected threaded one.

Typical construction principle - prone to leaking!

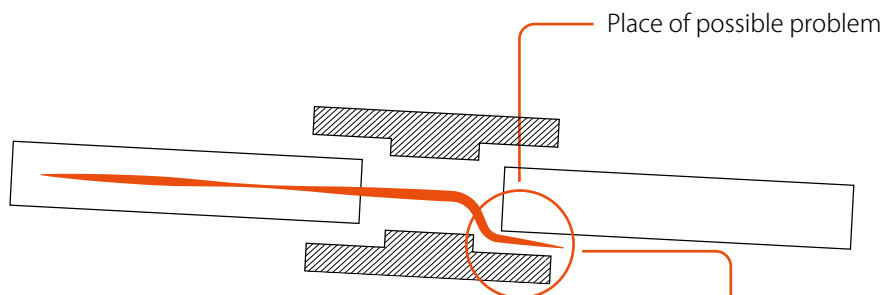

Smooth pipe ends are interconnected, using connecting sleeves.
This results in increased danger of leakage.

Perfect integration, variable and safe

The SymLine pipe and tube system adapts to your laboratory equipment and can flexibly be integrated in the planning phase of new laboratory buildings or in existing work environments. Liquid waste can flow from several work stations via pipe elements and tubes to a central collection point. No hazardous waste containers in the work area! Liquid waste transferred safely and compliantly between the work and storage areas.



Example illustration, HPLC, table and fume hood

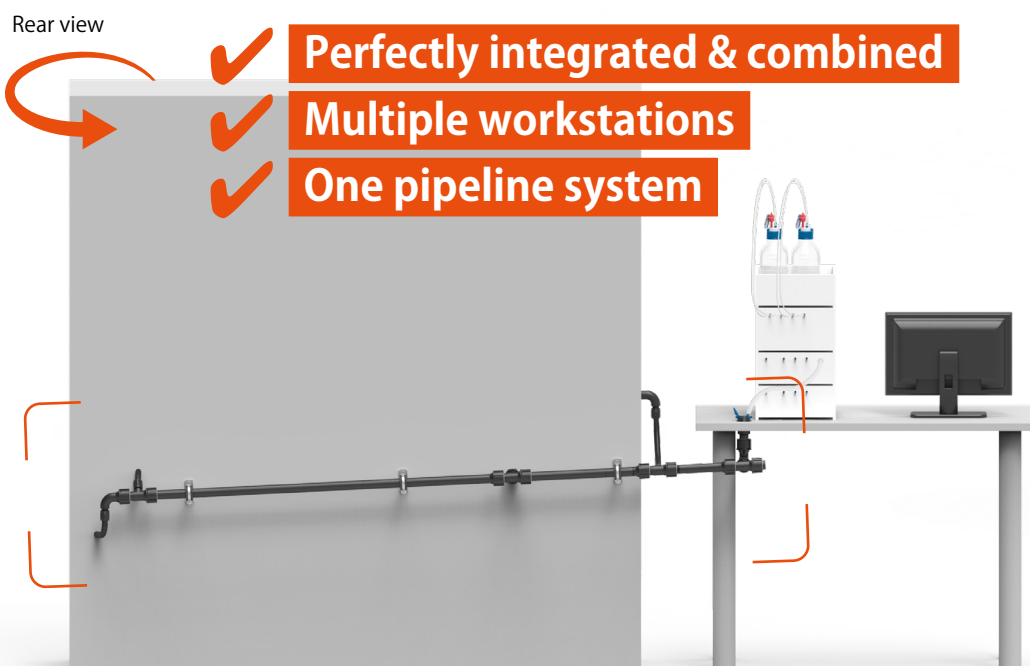

Back side with pipe and tube system

Flexible in every detail

You are free to choose when installing and placing your filling units. Whether funnel, collection tray or table feed through, thanks to flexible tubes, pipe connections and numerous connecting pieces, every angle can be reached. Tubes and pipes are available in different lengths and can also be shortened according to your needs.

- ✓ Individually adaptable to each laboratory
- ✓ Reaches every angle

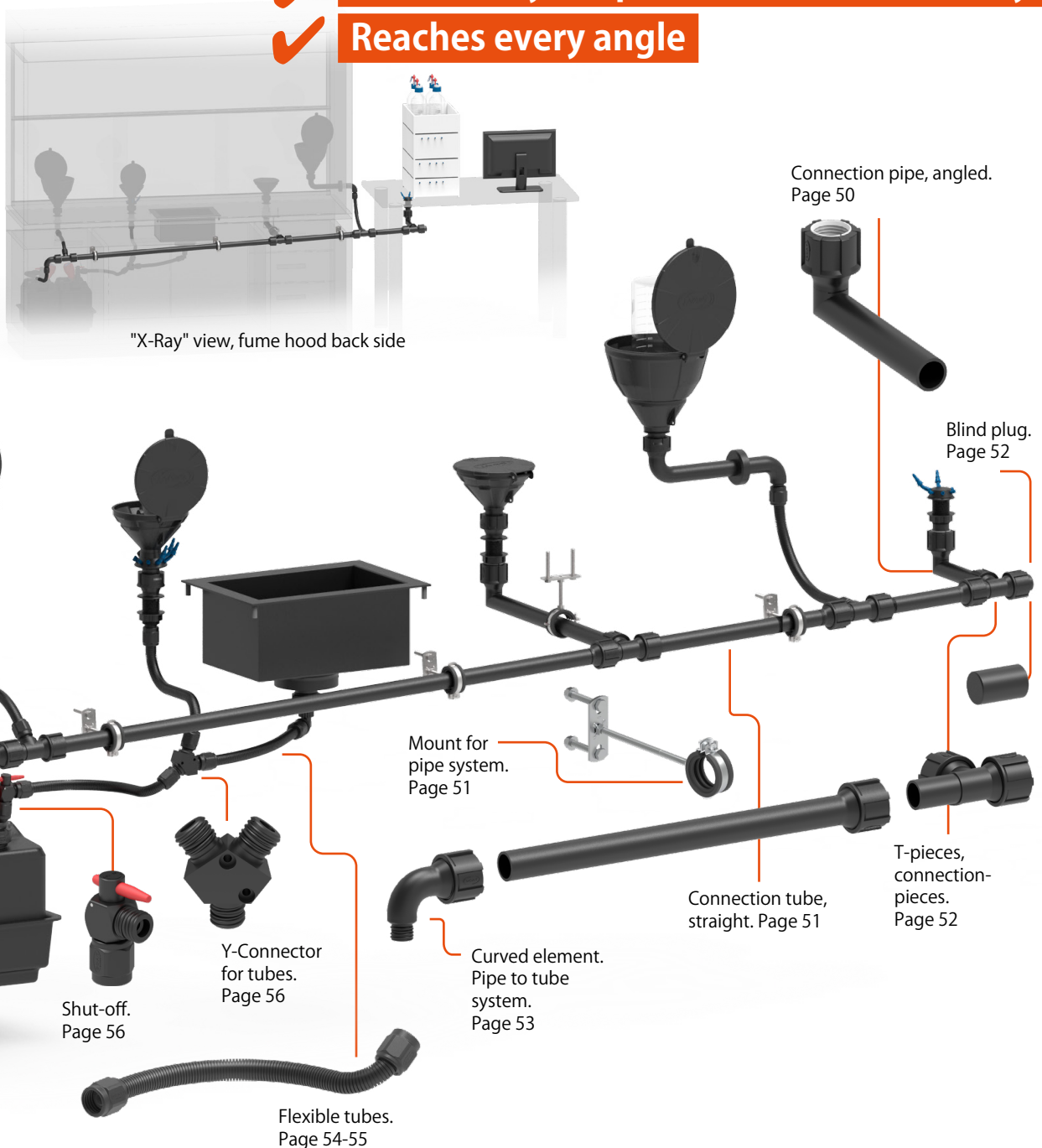

- A**
106 430
Connection pipe angled
- 1x (ID) Ø 32 mm
 - 1x (OD) Ø 32 mm
 - L = 150 mm
 - $\alpha = 93^\circ$
 - Material: PE-HD-EL

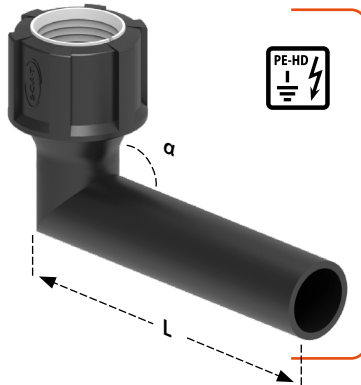

Connection pipes, angled, with 3° incline



- Screw connection with Ø 32 mm inner diameter, end piece with Ø 32 mm outer diameter
- 3° incline
- PE-HD electrostatically conductive
- Can be combined with desktop mounts, connectors and grounding clip

- B**
106 438
Connection pipe angled
- 1x (ID) Ø 32 mm
 - 1x (OD) Ø 32 mm
 - L = 200 mm
 - $\alpha = 93^\circ$
 - Material: PE-HD-EL



Angled pipe pieces connected to feedthroughs, serve as the start of each disposal route below the work area

- C**
106 440
Connection pipe angled
- 1x (ID) Ø 32 mm
 - 1x (OD) Ø 32 mm
 - L = 500 mm
 - $\alpha = 93^\circ$
 - Material: PE-HD-EL

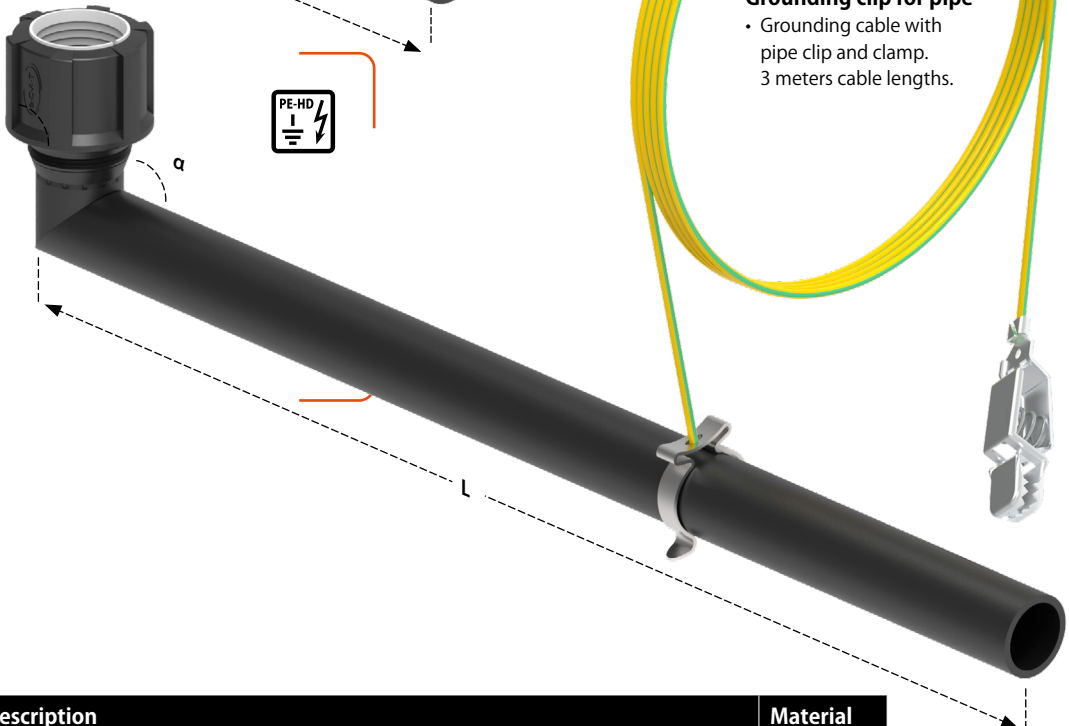

- D**
108 176
Grounding clip for pipe
- Grounding cable with pipe clip and clamp. 3 meters cable lengths.

Fig.	Part No.	Description	Material
A	106 430	Connection pipe angled, 1x (ID) Ø 32 mm, 1x (OD) Ø 32 mm, length 150 mm	PE-HD-EL
B	106 438	Connection pipe angled, 1x (ID) Ø 32 mm, 1x (OD) Ø 32 mm, length 200 mm	PE-HD-EL
C	106 440	Connection pipe angled, 1x (ID) Ø 32 mm, 1x (OD) Ø 32 mm, length 500 mm	PE-HD-EL
D	108 176	Grounding clip for Ø 32 mm pipe, with cable and clamp, 3 m length	

Connection pipes, straight

- Screw connection with \varnothing 32 mm inner diameter, end piece \varnothing 32 mm outer diameter
- PE-HD electrostatic conductive
- Can be combined with angled connection pipes, connection pieces and grounding clip

A

106 690 Connection pipe straight

- 1x (ID) \varnothing 32 mm
- 1x (OD) \varnothing 32 mm
- L = 600 mm
- Material: PE-HD-EL



The SymLine construction:

- 1x threaded connector (ID) \varnothing 32mm
- 1x smooth tube end (OD) \varnothing 32mm

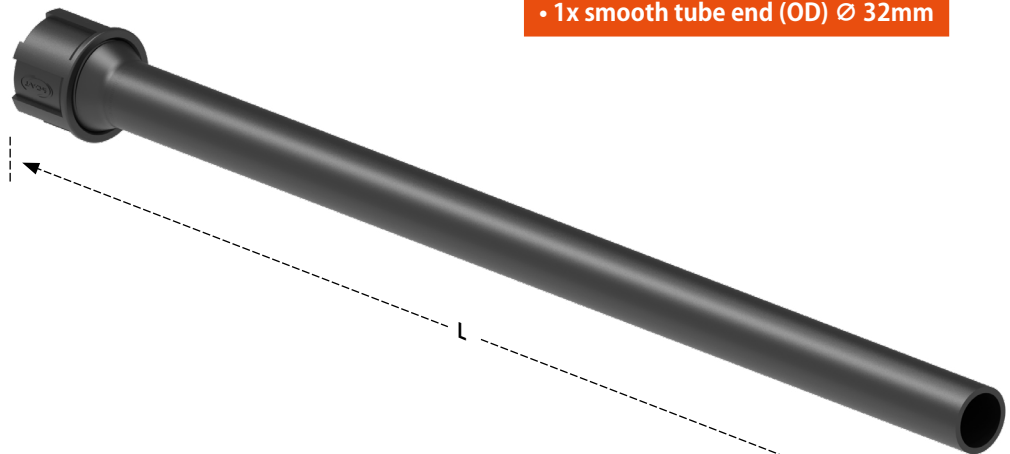

Connection pipes are preconfigured in different lengths and can be shortened at their smooth side

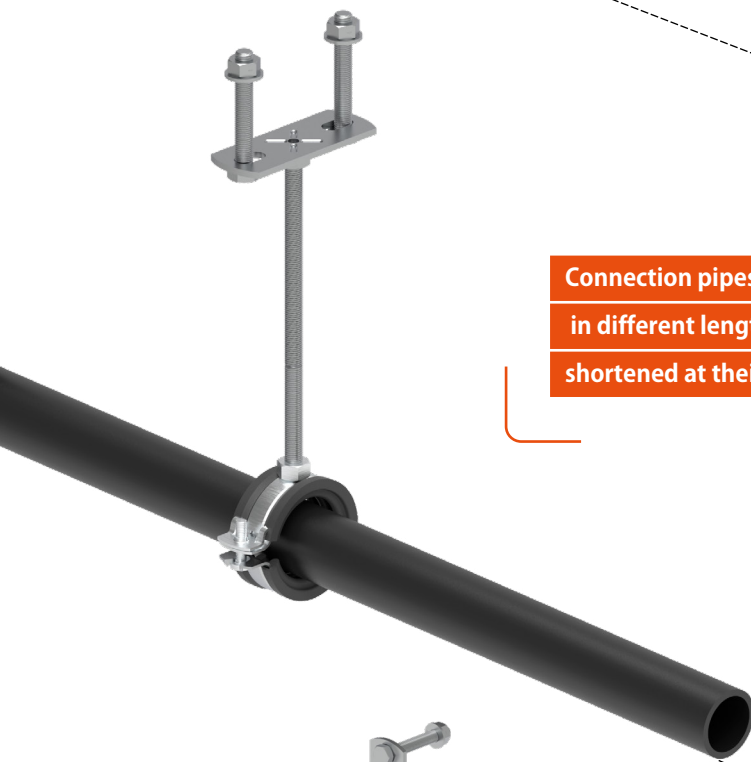

B

106 609 Attachment for pipe system

- including screws

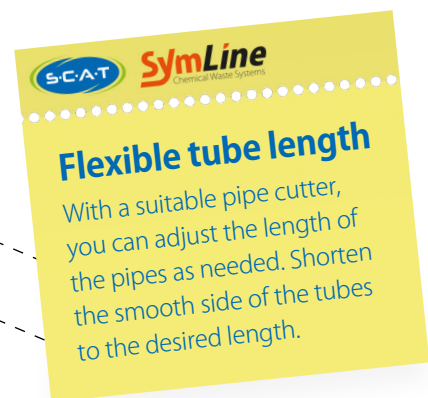

Fig.	Part No.	Description	Material
A	106 690	Connection pipe, straight, 1x (ID) \varnothing 32 mm, 1x (OD) \varnothing 32 mm, length 600 mm	PE-HD-EL
	106 700	Connection pipe, straight, 1x (ID) \varnothing 32 mm, 1x (OD) \varnothing 32 mm, length 1200 mm	PE-HD-EL
B	106 609	Attachment for pipe system \varnothing 32 mm	

A

106 712

T-Piece for pipes

- 2x (ID) Ø 32 mm
- 1x (OD) Ø 32 mm
- Dimensions: 120 x 93 x 56 mm
- Material: PE-HD-EL
- Can be combined with table feedthrough, angled and straight connection pipes



Connectors

- Screw connection with Ø 32 mm inner diameter, end piece Ø 32 mm outside diameter
- PE-HD electrostatic conductive
- Can be combined with pipe and tube system



• Can be used variably

• Every angle reachable

B

106 423
Blind plug

- (OD) Ø 32 mm
- Dimensions: 50 mm
- Material: PE-HD-EL

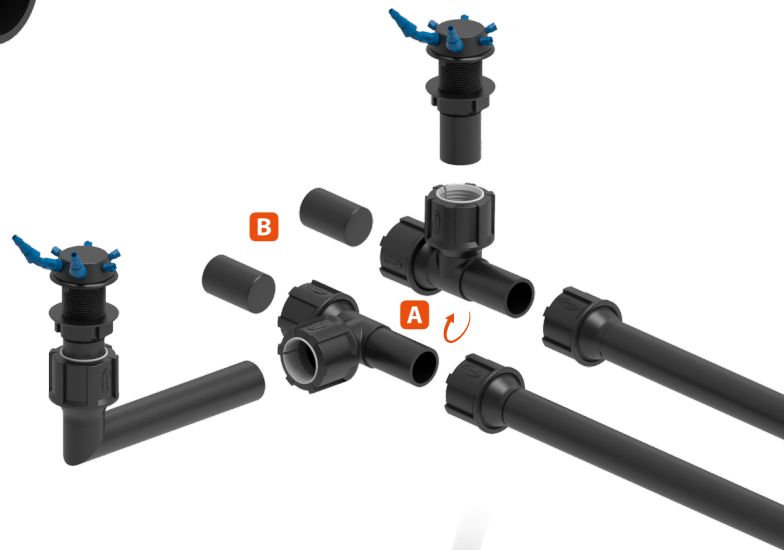
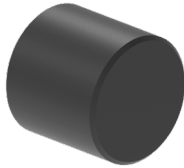

C

106 711
T-Piece for pipes with GL25 (m)

- 1x (ID) Ø 32 mm
- 1x GL25 (m)
- 1x (OD) Ø 32 mm
- Dimensions: 120 x 70 x 56 mm
- Material: PE-HD-EL



GL25 (m)

SymLine tube connection



Fig.	Part No.	Description	Material
A	106 712	T-Piece, 2x Ø (ID) 32 mm, 1x Ø (OD) 32 mm	PE-HD-EL
B	106 423	Blind plug for pipe Ø (OD) 32 mm	PE-HD-EL
C	106 711	T-Piece, 1x Ø (ID) 32 mm, 1x GL25 (m), 1x Ø (OD) 32 mm	PE-HD-EL

- A**
106 421
Curved element for pipes
- 1x (ID) Ø 32 mm
 - 1x (OD) Ø 32 mm
 - Dimensions: 92 x 90 x 56 mm
 - Material: PE-HD-EL



- Can be used variably
- Every angle reachable



Curved elements

- Screw connection with Ø 32 mm inner diameter, end piece Ø 32 mm outside diameter or GL25 tube connection
- PE-HD electrostatic conductive
- Can be combined with pipe and tube system

- B**
106 457
Curved element pipe to tube with 3° incline
- 1x (ID) Ø 32 mm
 - 1x GL25 (m)
 - Dimensions: 76 x 76 x 56 mm
 - Material: PE-HD-EL



- C**
106 456
Curved element pipe to tube
- 1x (ID) Ø 32 mm
 - 1x GL25 (m)
 - Dimensions: 84 x 90 x 56 mm
 - Material: PE-HD-EL



GL25 (m)
SymLine tube connection



Fig.	Part No.	Description	Material
A	106 421	Curved element, Ø (ID) 32 mm to Ø (OD) 32 mm	PE-HD-EL
B	106 457	Curved element with 3° incline, Ø (ID) 32 mm to GL25 (m)	PE-HD-EL
C	106 456	Curved element, Ø (ID) 32 mm to GL25 (m)	PE-HD-EL

A B C D

106 569

**FlexTube
GL25 (f)**

- 2x GL25 (f)
- Material: PTFE-EL

- Can be assembled - easy installation. If necessary, shorten tubes flexibly, then mount the optimised screw connection and seal.

- 
- Fitting & bracket included

• Spiral inner wall

• Increased bending radius (≥ 25 mm)

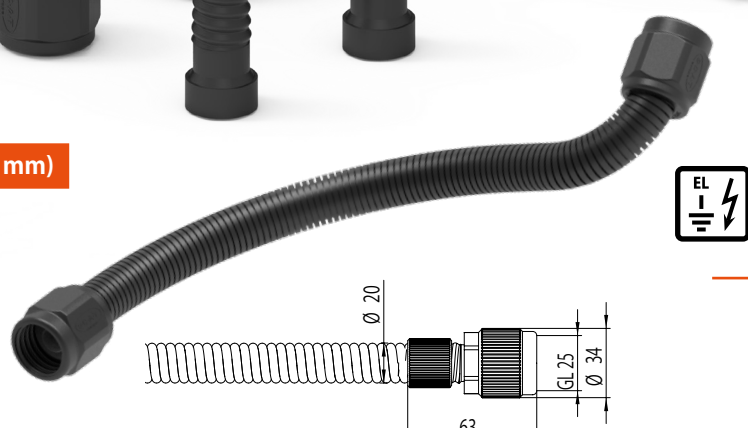

FlexTube, inner wall spiral

- PTFE for the best possible chemical resistance
- Electrostatic conductive $< 10^6$ (max) Ω
- \varnothing 19.8 mm outer diameter
- \varnothing 11.5 mm inner diameter

Installation guide



All media-touching parts made of PTFE-EL

Fig.	Part No.	Description	Material
A	106 569	SymLine [®] FlexTube GL25 (f), length 600 mm, \varnothing 19.8 mm OD	PTFE-EL
B	106 568	SymLine [®] FlexTube GL25 (f), length 1000 mm, \varnothing 19.8 mm OD	PTFE-EL
C	106 567	SymLine [®] FlexTube GL25 (f), length 1500 mm, \varnothing 19.8 mm OD	PTFE-EL
D	106 566	SymLine [®] FlexTube GL25 (f), length 2500 mm, \varnothing 19.8 mm OD	PTFE-EL
E	108 270	Grounding cable for SymLine [®] FlexTube, with cable and clamp, 3 m	

A B C D

**106 575
FlexTube Pro
GL25 (f)**

- 2x GL25 (f)
- Material: PTFE-EL



- Fitting & bracket included

• Smooth inner wall

• Avoids deposits

• Bending radius (> = 60 mm)

- Can be assembled - easy installation. If necessary, shorten tubes flexibly, then mount the optimised screw connection and seal.

**FlexTube Pro,
inner wall smooth**

- PTFE for the best possible chemical resistance
- Electrostatic conductive < 10⁶ (max) Ω
- Ø 16.9 mm outer diameter
- Ø 10.7 mm inner diameter



All media-touching parts made of PTFE-EL

i Installation guide

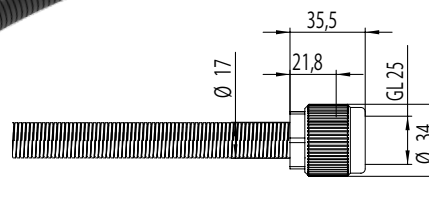

E

**108 270
Grounding cable for tube**

- Grounding cable with tube clip and clamp, 3 meter cable length.



Fig.	Part No.	Description	Material
A	106 575	SymLine® FlexTube Pro GL25 (f), length 600 mm, Ø 16.9 mm OD	PTFE-EL
B	106 574	SymLine® FlexTube Pro GL25 (f), length 1000 mm, Ø 16.9 mm OD	PTFE-EL
C	106 573	SymLine® FlexTube Pro GL25 (f), length 1500 mm, Ø 16.9 mm OD	PTFE-EL
D	106 572	SymLine® FlexTube Pro GL25 (f), length 2500 mm, Ø 16.9 mm OD	PTFE-EL
E	108 270	Grounding cable for SymLine® FlexTube, with cable and clamp, 3 m	

A

106 475

Shut-off valve, angled

- 1x GL25 (f)
- 1x GL25 (m)
- Dimensions: 60 x 86 x 36 mm
- Material: PTFE-EL

• Stops the flow of waste liquids into the canister. Drip-free canister change or emptying.

• Compatible with Safety Waste Caps, connectors, manifolds and the SymLine FlexTube's.



B

106 476

Y-Distributor

- 3x GL25 (m)
- Dimensions: 68 x 69 x 36 mm
- Material: PE-HD-EL

• Merging two SymLine FlexTube's to one exit. Two 0.5 mm holes for wall mounting.

• Compatible with the SymLine FlexTube's.

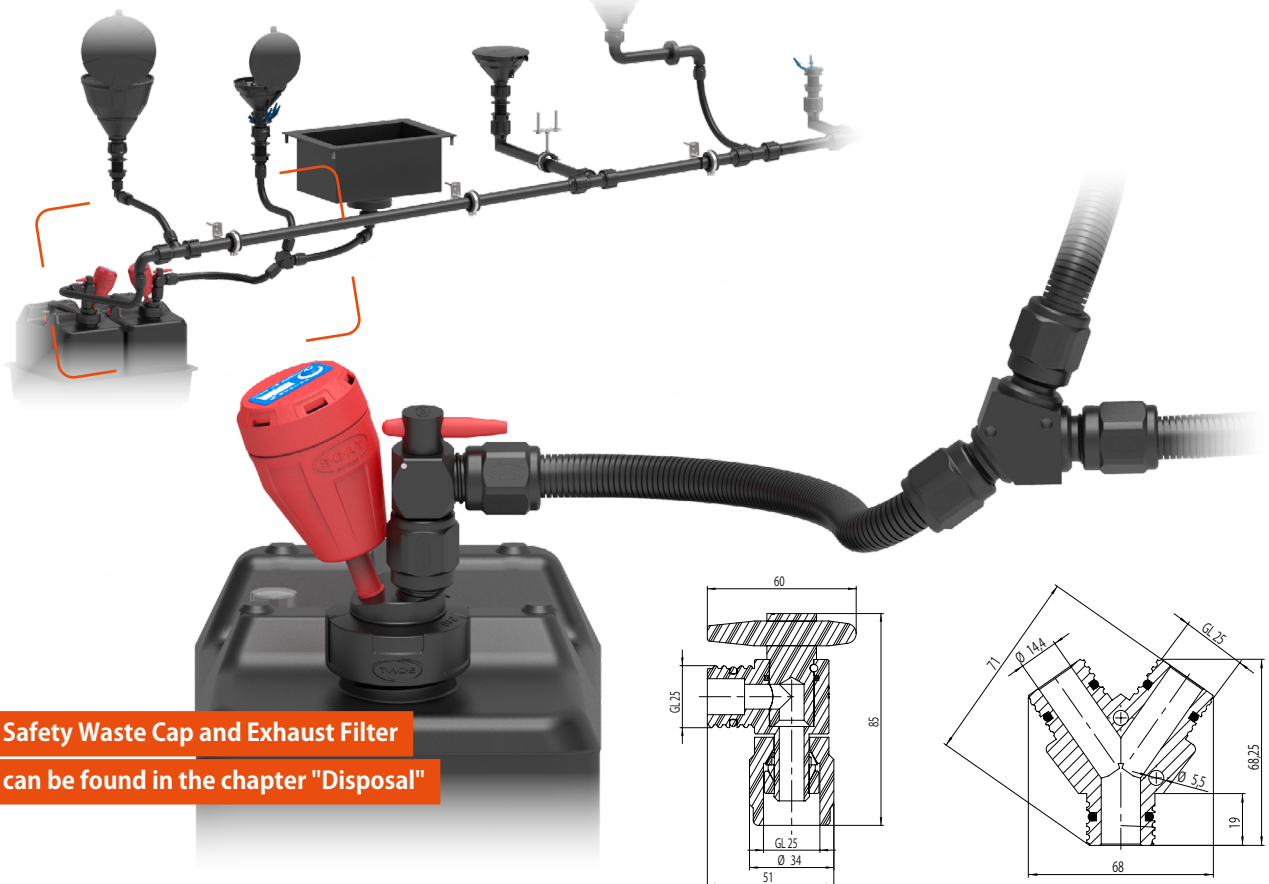

Safety Waste Cap and Exhaust Filter can be found in the chapter "Disposal"

Fig.	Part No.	Description	Material
A	106 475	Shut-off, angled, 1x GL25 (w) to 1x GL25 (m), incl. spanner	PTFE-EL
B	106 476	Y-Distributor, 3x GL25 (m), with 2 mounting holes	PE-HD-EL

A

106 611

Cabinet feed-through

- Feedthrough in safety cabinets with wall thickness max. 100 mm and bore \varnothing 35 mm, lock nut with silicone seals for clamp mounting.
- 2x GL25 (m)
- Dimensions: 35 x 56 x 189 mm
- Material: PE-HD-EL
- Compatible with fire protection attachment 106 605



B

106 605

Fire protection package

- Sheet metal housing with plaster insert for fire protection of cabinet or pipe feedthroughs in safety cabinets, undrilled.
- Incl. 4 fastening screws.
- Dimensions: 182 x 104 x 48 mm

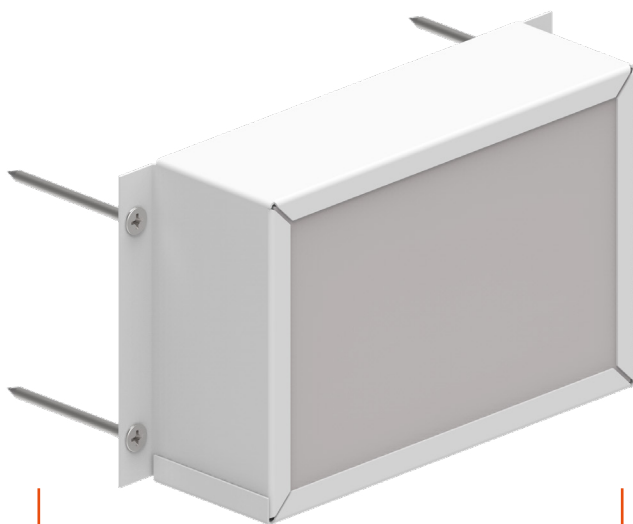

Fig.	Part No.	Description	Material
A	106 611	Cabinet feed-through, angled, 2x GL25 (m)	PE-HD-EL
B	106 605	Fire protection package, sheet metal housing with plaster insert, 4x fastening screws	