

Bildanleitung   
*Illustrated manual* 



- **SymLine<sup>®</sup> FlexTube Pro**  
Installation



- **SymLine<sup>®</sup> FlexTube**  
Installation



- **Schlauchhalter / Tube Mount**  
Installation

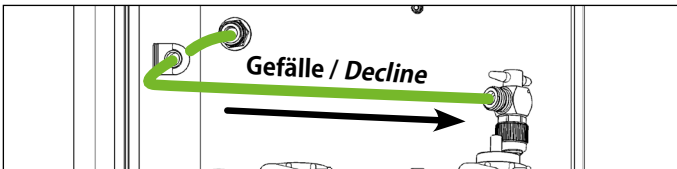

- **Schlauchhalter / Tube Mount**  
✓ Do's and Don'ts! ✗

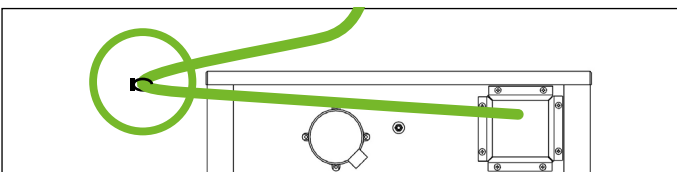

- **Schlauchführung / Tube guide**  
✓ Do's and Don'ts! ✗

<p><b>ACHTUNG VOR DEM BEWEGEN DES SICHERHEITSSCHRANKS!</b> <b>BITTE ENTFERNEN SIE ZUERST DIE OBERE BLENDE!</b></p> <p>Bitte ENTFERNEN Sie beim Einbau des Sicherheitsschranks und der Installation des Abfallschlauchs, sowie bei Wartungen des Systems, vor dem Bewegen des Sicherheitsschranks (Einschieben und Herausziehen) die obere BLENDE!</p> <p>Achten Sie bei der Installation und Wartung des Systems auf eine korrekte Führung des Abfallschlauchs, gleichmäßiges Gefälle, keine Sackbildungen oder Knicken!</p> <p>Lösen Sie den Abfallschlauch vor dem Herausziehen des Sicherheitsschranks aus der seitlichen Schlauch-Klemmhalterung!</p>		<p><b>ATTENTION BEFORE MOVING THE SAFETY CABINET!</b> <b>FIRST OF ALL PLEASE REMOVE FRONT PANEL!</b></p> <p>Before installing the safety cabinet and mounting the waste tube, as well during maintenance, REMOVE the FRONT PANEL before moving the safety cabinet! (Pushing in and pulling out.)</p> <p>During installation and maintenance please ensure a correct guidance of the waste tube, a consistent slope and avoid sagged or kinked tubes!</p> <p>Remove waste tube from side tube clamp holder before pulling out the safety cabinet!</p>
<p><b>STOP! STOPP! STOP!</b></p>	<p><b>SymLine</b> </p>	<p><b>STOP! STOP! STOP!</b></p>

- **Aufkleber / Sticker**  
Sicherheitsschrank /  
*Safety cabinet*



# FlexTube Pro Installation



Lieferumfang  
Scope of delivery

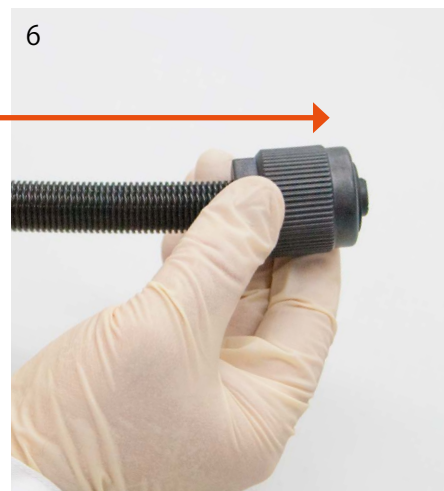
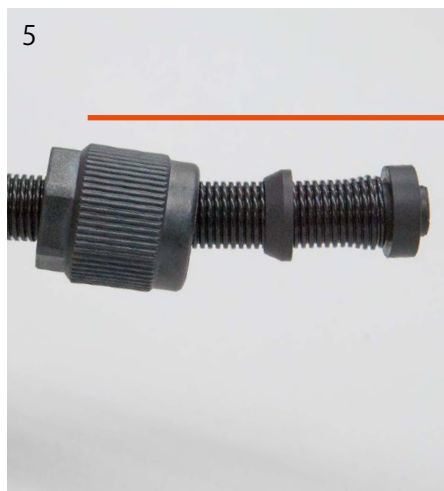
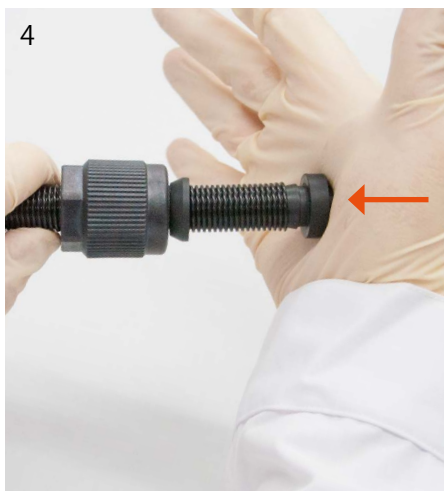
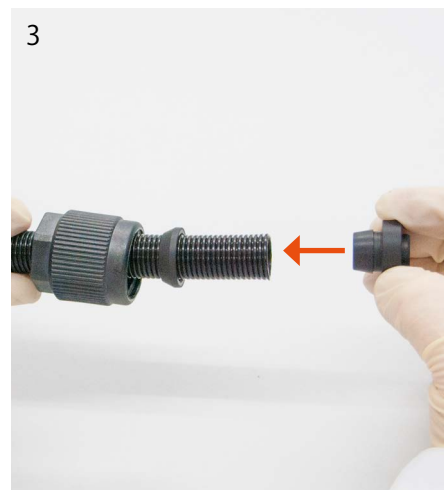
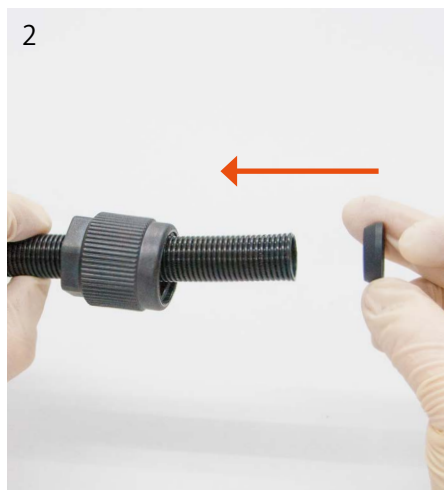
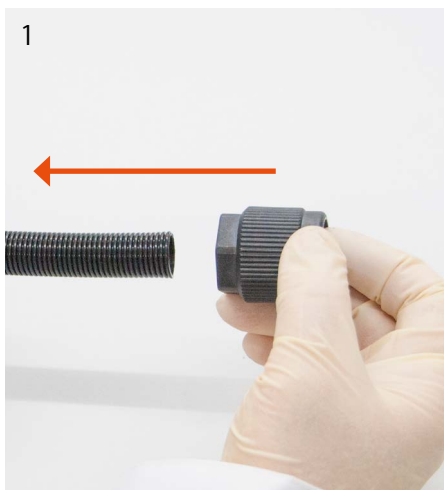

Absperrhahn nicht im Lieferumfang enthalten.  
Shut-off not included in the scope of delivery.

# FlexTube Installation



Lieferumfang  
Scope of delivery

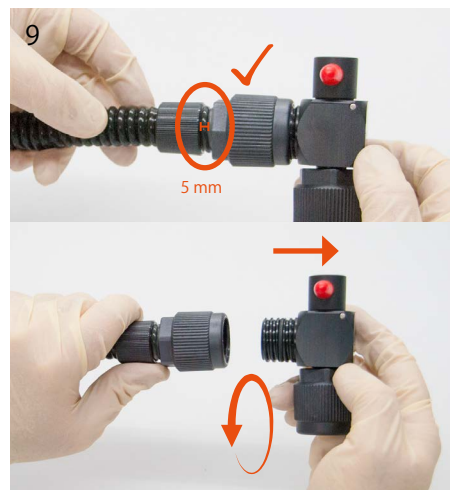
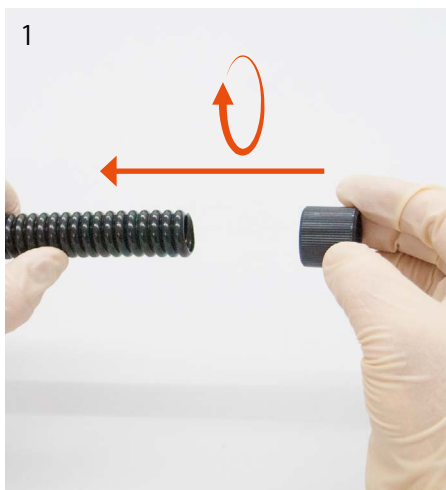





Lieferumfang  
Scope of delivery

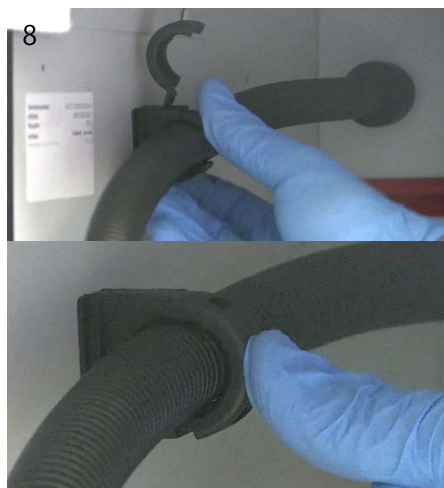
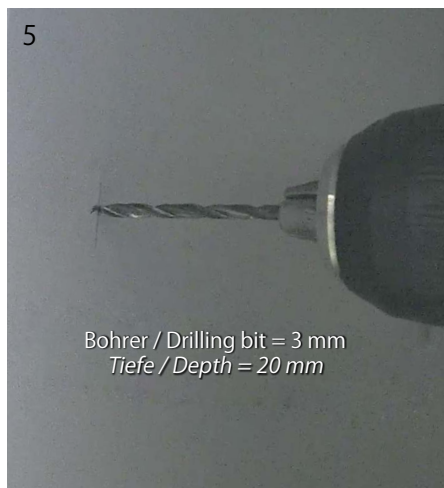
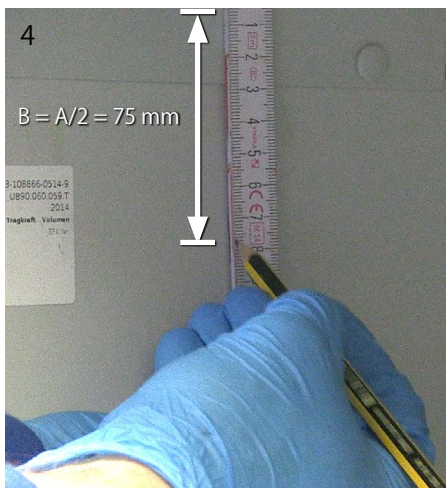
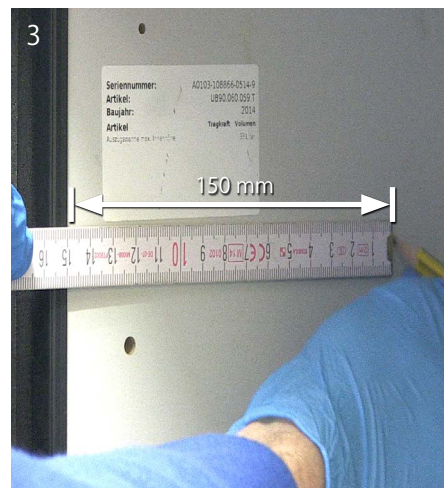
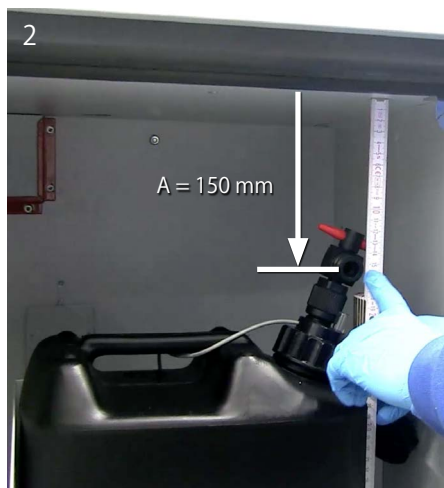
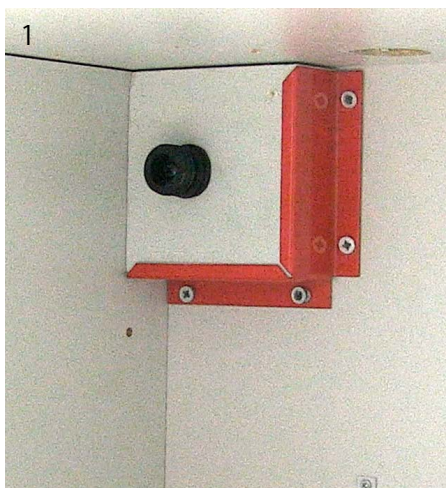

# Schlauchhalter / Tube Mount

✔ Do's and Don'ts! ✘

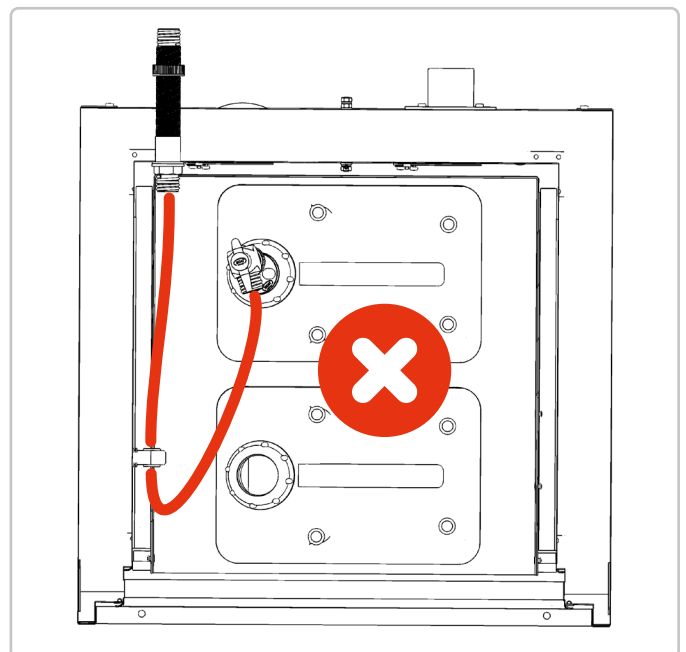
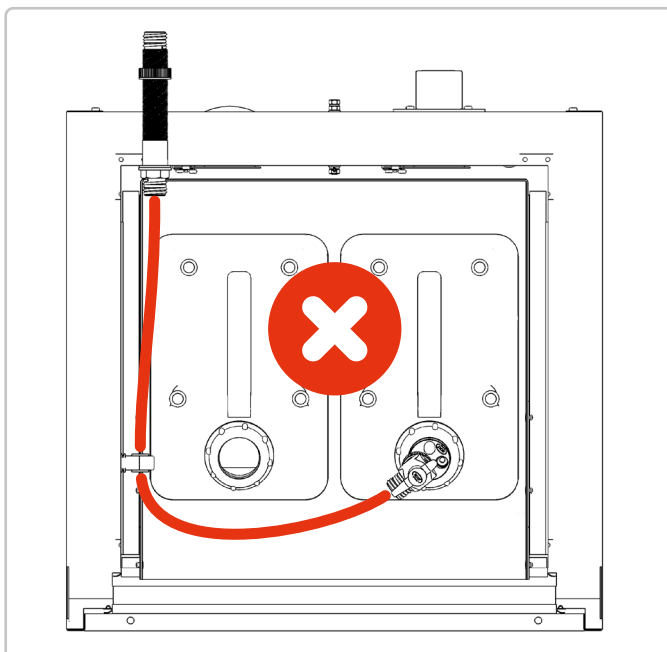
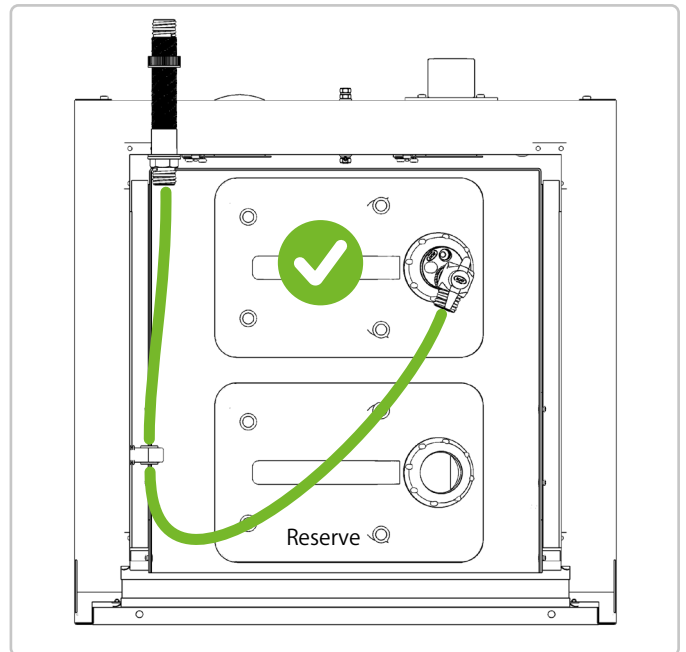
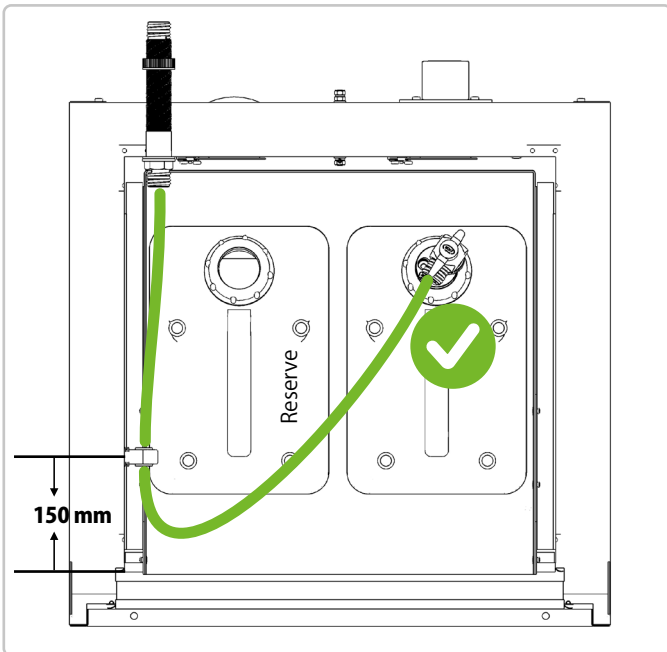
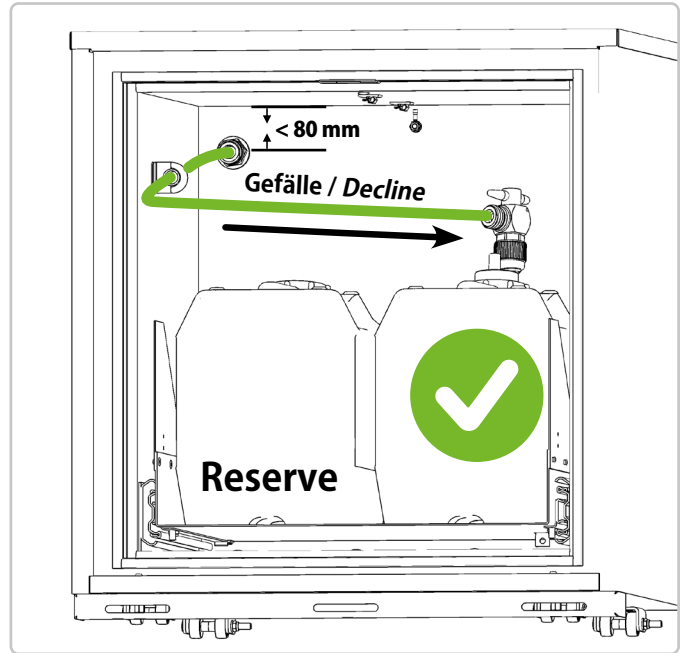

✔ Do's and Don'ts! ✘

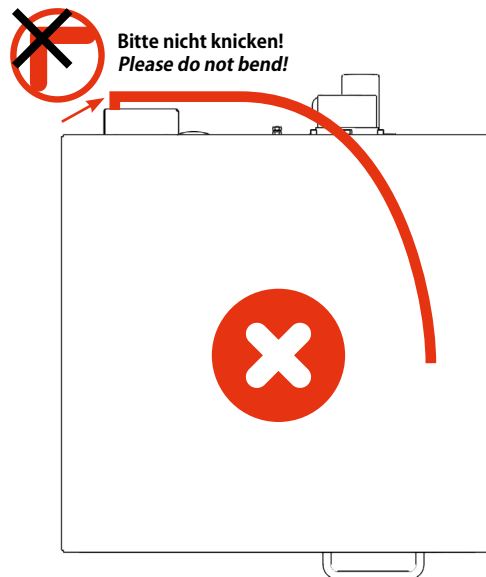
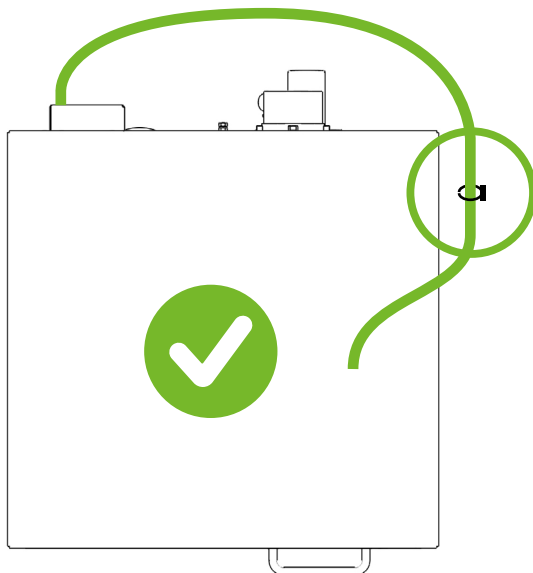
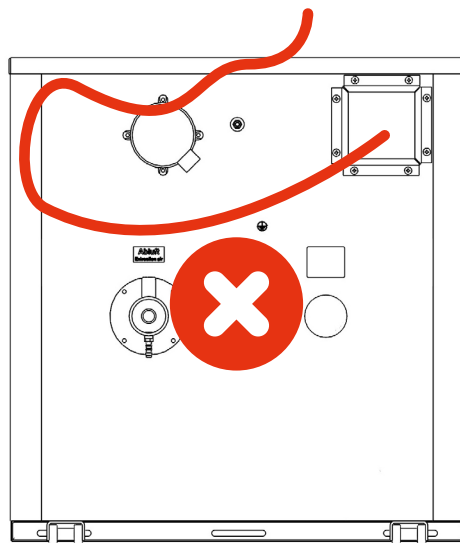
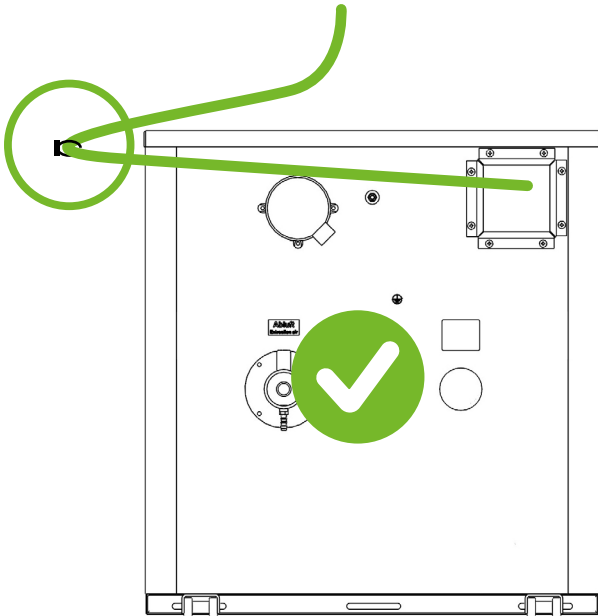
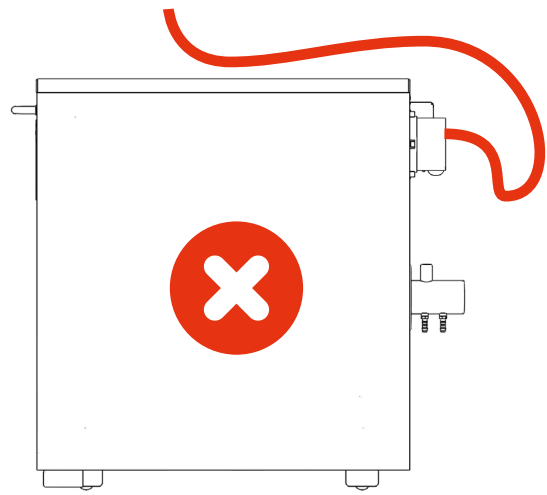
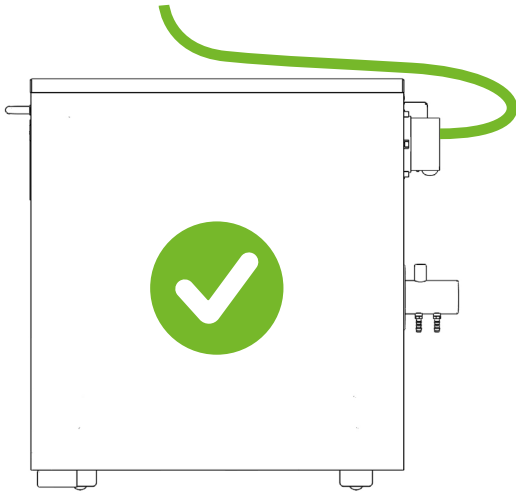

**Bitte den beigefügten Aufkleber auf der Oberseite des Sicherheitsschranks, an der vorderen Kante aufbringen.**

**Please attach the enclosed sticker on the top of the safety cabinet, at the front edge.**

**ACHTUNG VOR DEM BEWEGEN DES SICHERHEITSSCHRANKS!**  
**BITTE ENTFERNEN SIE ZUERST DIE OBERE BLENDE!**

Bitte ENTFERNEN Sie beim Einbau des Sicherheitsschranks und der Installation des Abfallschlauchs, sowie bei Wartungen des Systems, vor dem Bewegen des Sicherheitsschranks (Einschieben und Herausziehen) die obere BLENDE!

Achten Sie bei der Installation und Wartung des Systems auf eine korrekte Führung des Abfallschlauchs, gleichmäßiges Gefälle, keine Sackbildungen oder Knickel!

Lösen Sie den Abfallschlauch vor dem Herausziehen des Sicherheitsschranks aus der seitlichen Schlauch-Klemmhalterung!

**ATTENTION BEFORE MOVING THE SAFETY CABINET!**  
**FIRST OF ALL PLEASE REMOVE FRONT PANEL!**

Before installing the safety cabinet and mounting the waste tube, as well during maintenance, REMOVE the FRONT PANEL before moving the safety cabinet! (Pushing in and pulling out.)

During installation and maintenance please ensure a correct guidance of the waste tube, a consistent slope and avoid sagged or kinked tubes!

Remove waste tube from side tube clamp holder before pulling out the safety cabinet!

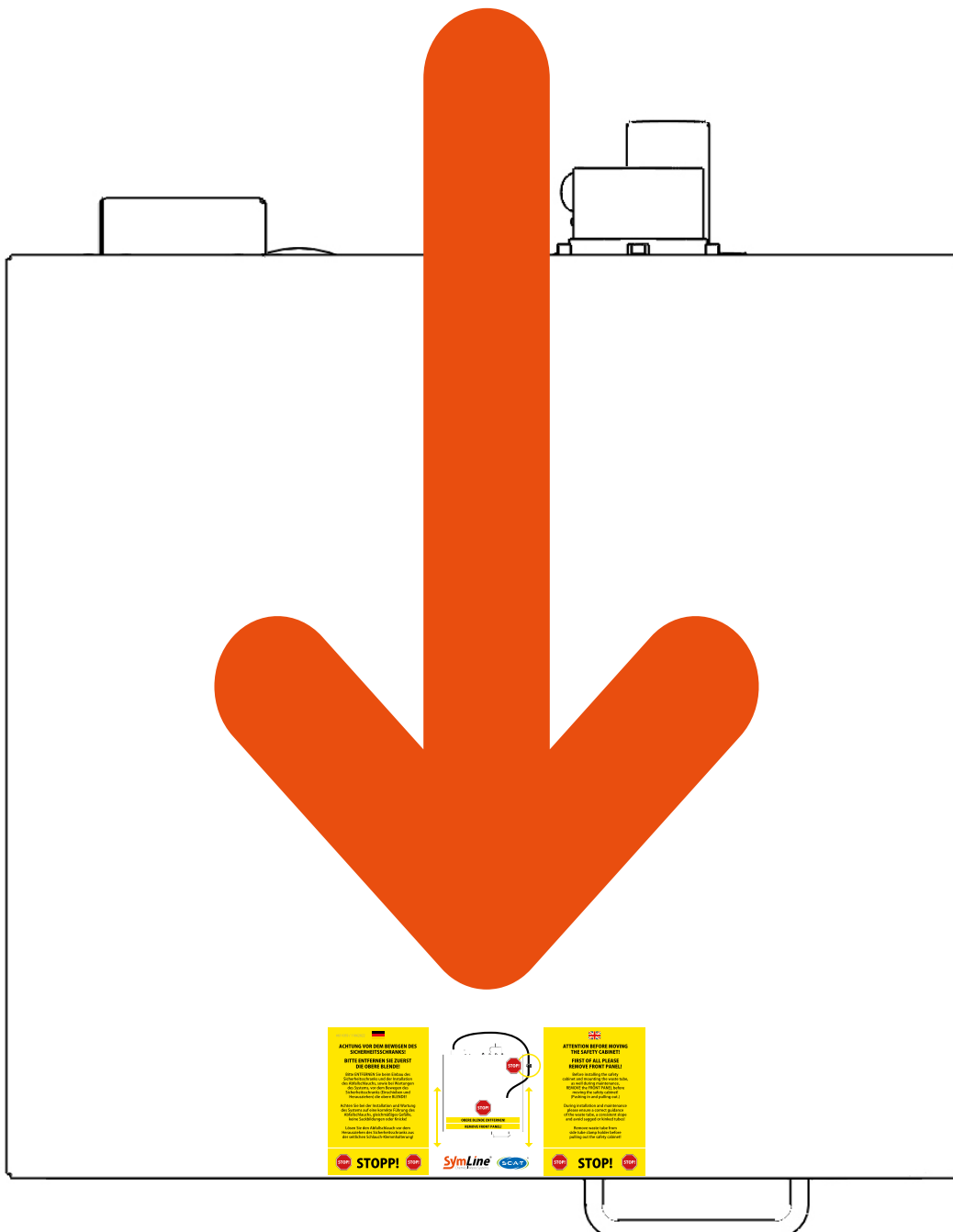

**SymLine**<sup>®</sup>  
Chemical Waste Systems



SCAT Europe GmbH  
Waldecker Straße 7  
64546 Mörfelden  
Deutschland / Germany

Tel: + 49 - (0) 6105 - 305 586 - 0  
Fax: + 49 - (0) 6105 - 305 586 - 99  
e-Mail: [info@scat-europe.com](mailto:info@scat-europe.com)  
Web: [www.scat-europe.com](http://www.scat-europe.com)

Ihr Fachhändler vor Ort:  
Your local distributor: